

» **Technical SPECIFIKACIONES**

External filling

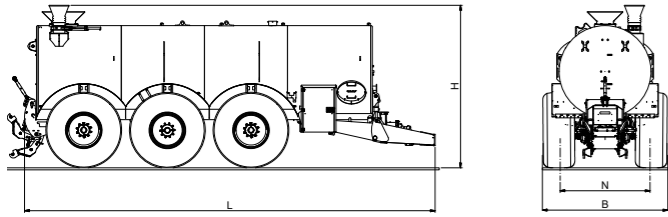

Pump tower

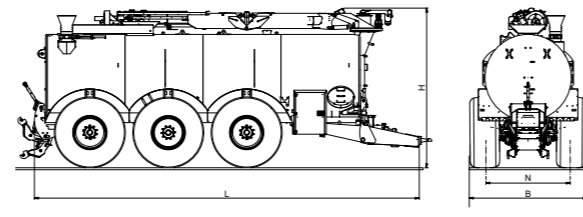

Ejector

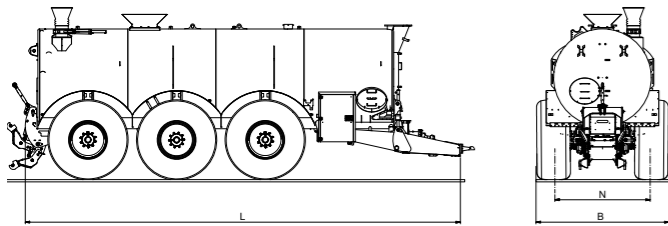

Pump tower and ejector

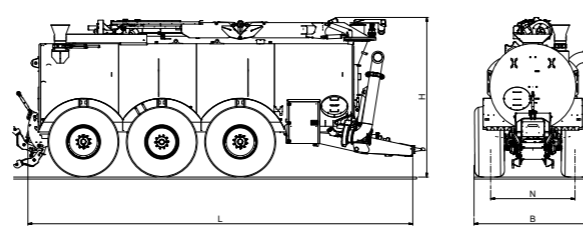

Pump tower

SAP 1 (Mk 2)

SAP 2 (Mk 2)

SAP 2 (Mk 2)

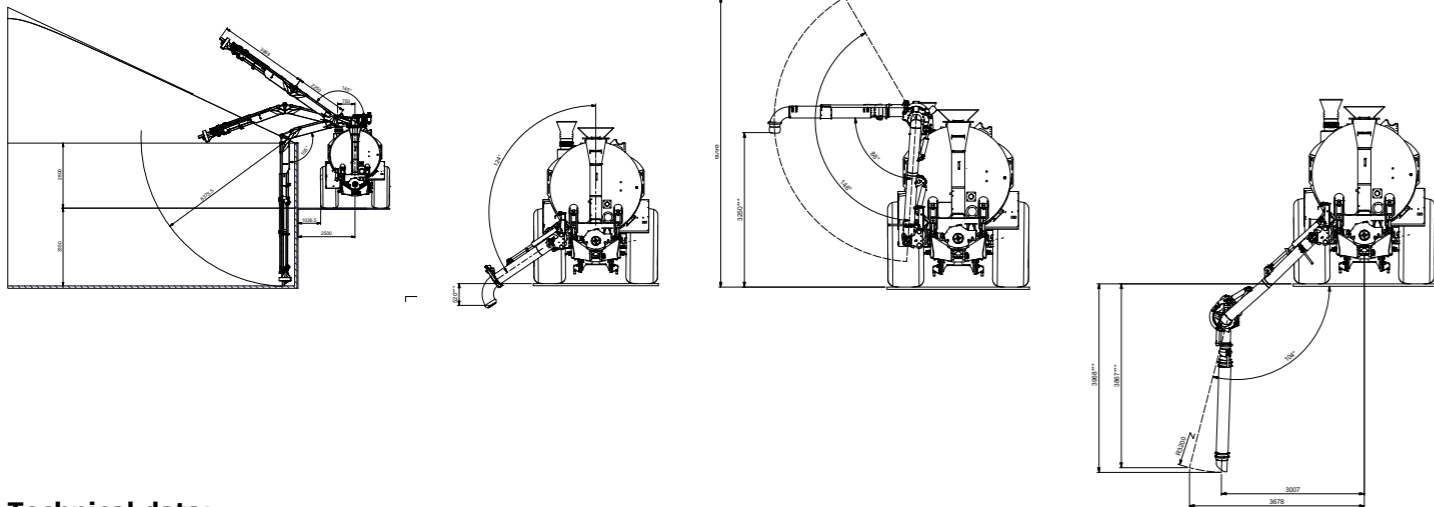

Technical data:

Dimensions in mm / Tanker size		PG II 28	PG II 31	PG II 35
Lenght	L	10165	10815	11815
Tank diameter	Ø		2200	
Height*	H		4000	
Alliance, 650/65R38 MULTIUSE 550	B		2895	
Alliance, 800/60-R32 - Radial type 390	B		3000	
Nokian, 800/60-R34 - Radial type ELS SB	B		3000	
Hub width	N	2150	2150	2150
Unladen weight for basic tanker**, kg.		12585	12750	13125
Volume in m ³		27,8	30,9	34,5

* Max. height with either funnel or hydraulic pivoting discharge pipe with hydraulic switching.

** Unladen weight for basic tanker only fitted with standard equipment - without factory fitted optional extras and accessories.

Weight of selected equipment for basic tanker:

Lift (lifting arm, centre bracket and cylinder. NB: Part of the lift bracket is welded to the tank): 350 kg.

» **SAMSON Slurry Tanker**
PG II 28



- growing together



Improvements on PG II 28

Improved lift on front axle

The undercarriage of the PG II 28 has been modified to provide greater compression in the suspension system. This has increased clearance between the wheels and the ground considerably. The axle lift can now also be operated by pressing a short-cut key on the SlurryMaster 8000 joystick. The wider clearance makes it possible to substantially increase the pressure on the drawbar eye. This is a great help when you have to drive up steep hills pulling heavy implements.

PG II 28 slurry tanker

With the 2017/2018 price list, SAMSON AGRO is launching a new model in the PG II slurry tanker series: the PG II 28. This will allow every combination of implement and filling solution on slurry tankers in the PG II series. PG II 28 replaces PG II 27. The PG II series is thus available as a 2-axle version in the sizes PG II 16, PG II 18 and PG II 20 and a 3-axle version in the sizes PG II 21, PG II 25, PG II 28, PG II 31 and PG II 35.

The development of slurry implements has accelerated in recent years, and customer demands for complete flexibility to choose filling systems, regardless of implement, have been intensifying. This explains why this new tanker has been lengthened to provide more space for large drip hose booms. Several tanker features have also been brought up to date to match the requirements of professional users. The tanker is being introduced as a standard model and a popular version featuring hydraulic wheel drive (HWD).



The PG II series offers many exciting features such as an ejector pump, hydraulic wheel drive (HWD), SAP suction arms, easy to use control system with touch screen and joystick (SlurryMaster 8000), and various sensors that can help the driver to apply the slurry optimally and prevent damage to the equipment.

Same design and construction

PG II 28 has the same design as the other tankers in the PG II series. The tank is positioned horizontally on two strong and through-going profiles and equipped with three anti-surge partitions for improved stability. The tank has an internal sloped floor to ensure optimal supply to the discharge pump at the front end of the slurry tanker. PG II 28 is fitted with large wheels just like the other large slurry tankers in the PG II series. These have a diameter of 182 cm. They reduce the need for traction and prolong tyre life. They also apply less pressure on the soil and reduce driving damage. The tank on the PG II 28 is 35 cm longer than on the PG II 27. In addition, the frame has been raised 5 cm in the tank. This allows all types of implements to be combined with all types of filling solutions. At the same time, there is increased weight transfer to the trailer coupling, with the benefits that this brings.

Improvements on PG II 28

New 3-point hitch position

The pivot point of the 3-point hitch/linkage has been lowered to improve the tractor pull lines over the implement. The implement can thus work more freely, while reducing the load on the implement and the hitch/linkage. It will counter increasing demands on the hitch/linkage as the implements get bigger and bigger. This change will also be introduced on the PG II 31 and PG II 35

Popular optional extras for the export markets

SlurryMaster8000

SlurryMaster 8000 is the name of SAMSON AGRO's new touch screen control system with a joystick. The system has been designed with a focus on the driver. The result is an easy to operate system with an intuitive and user friendly interface. This is a stand-alone system designed solely for the operation of slurry tankers, so no compromises have been made, which would have been the case if there had been used a standard platform that had to fit many different machines. To make the system more manageable for the driver, the system is divided into 3 user interfaces: fill, road and field. These only display the functions and settings that are required in each particular work situation. In other words, during filling, on the road or in the field. The driver can switch between the 3 modes with a single push on the joystick. It is possible to have up to 3 different implement settings, a help screen can be called up for the joystick, the system can accommodate up to 18 customer jobs and 1 season counter, and the system is equipped with several tools which make it very easy to service and troubleshoot.



SlurryMaster 8000

Different sensors

There is an option for a "return to centre" function on the pump tower on PG II tankers with the SlurryMaster 8000 control system. Two sensors installed under the rim of the pump tower control the pivot function. When the pump tower returns to the transport position, its speed decreases before stopping completely. An audio signal alerts the driver that the centre position has been reached so they can then easily lower the

pump tower into the waste tray. This is a great help for everyday operation of the slurry tanker.

If you choose the SlurryMaster 8000, a height sensor can also be purchased for the three-point lift/linkage. This allows even better control of the implement. And makes it easy to avoid exceeding the maximum transport height.



Revolutionary ejector

SAMSON AGRO has developed a brand new and powerful ejector vacuum pump system using the Venturi effect- hereafter referred to as the ejector. It is a sturdy pump that can pump anything, requires very little maintenance, has very low operating costs and it never loses its pumping power. The SAMSON AGRO ejector is a so-called inline ejector, whose design minimizes flow loss and optimizes vacuum formation. This type of ejector uses a highly recognized pumping technique in the maritime and offshore sector. The system's simplicity and sturdiness also make the ejector very usable when pumping in particularly difficult liquids.

To operate the SAMSON AGRO ejector, a small quantity of slurry has to be retained in the slurry tanker. The slurry is retained in a reservoir inside the tank. If the ejector is not being used, this slurry retention can be disconnected. The ejector can be used to fill the tanker under its own power via a hose connector on the side of the tanker, or to attach the centrifugal pumps to a fixed filling pump, SAP or pump tower. Using the centrifugal pumps achieves a higher output from the filling system. The ejector is fitted with a safety valve which ensures that the slurry can only enter the tank and not unintentionally run out again.

The inline ejector from SAMSON AGRO is both powerful and maintenance-free.